

INSTALLATION INSTRUCTION

1. INTRODUCTION

Ningbo Ulica Solar Co.,Ltd is a leading manufacturer of PV cells and modules, delivering reliability and competitive pricing on a global scale. We provide world-class PV technology, streamlined manufacturing, and local customer support.

We are committed to providing technical and installation support for our worldwide customers,.

This Installation Guide covers installation of the following Ulica modules

2. Applicable Module

UL-540M-144HV,UL-545M-144HV,UL-550M-144HV,UL-500M-132HV,UL-505M-132HV,UL-405M-108HV,UL-410M-108HV,UL-415M-108HV;

3. Mechanical Installation

3.1 Select a suitable location for installing the modules.

3.1.1 The modules should face south in northern latitudes and north in southern latitudes.

3.1.2 For detailed information on the best installation angle, refer to standard solar photovoltaic installation guides or consult a reputable solar installer or systems integrator.

3.1.3 Modules should not be shaded at any time. If a module is shaded or even partially shaded, it will fail to perform at ideal conditions and result in lower power output.

3.1.4 In general, we do not recommend to installing the PV system with a distance of less than 500 meters close to the coastline. If you plan to do so, please contact Ulica's Global Customer Service Department and/or refer to the Near-coast Installation Guide for Ulica Photovoltaic Module.

3.1.5 Do not use modules near equipment or in locations where flammable gases may be generated or collected.

3.1.6 In general, we do not recommend to installing the PV panel with a tilt angle less than 10 degree. In that case, the PV's generation will difficult to guarantee.

3.1.7 The modules should fixed 15cm from ground or roof .

3.2 Mounting and Notes

3.2.1 Systems should be installed by qualified professionals only. The process involves electricity and can be dangerous if the installing personnel are not familiar with the appropriate safety procedures.

3.2.2 The modules are qualified for application class A: Hazardous voltage (IEC 61730: higher than 50V DC; EN 61730: higher than 120V), hazardous power applications (higher than 240W) where general contact access is anticipated

(Modules qualified for safety through EN IEC 61730-1 and -2 within this application class are considered to meet the requirements for Safety Class II)”

- 3.2.3 Do not use modules of different configurations in the same system. When the modules connect in series, the voltage of the string cannot exceed the max system voltage, as reference the maximum number of modules (N) can be easily calculated by dividing the Maximum System Voltage of the modules by the respective Voc value of the module. When designing the PV system, please always take into consideration the variation of the voltage under different temperatures (please check the respective temp. coefficients of the modules, the Voc of the modules will be rise when the temperature drops); For example: with UL-300M modules (Max. System voltage is 1000V) the maximum series modules configuration number should NEVER can exceed $N = 17$ ($1000V/56.22V = 17.8$), taking into consideration the possible variation of the voltage due to the lowest temperature in winter at specified location can reach -40°C .
- 3.2.4 When PV modules connect in series, the voltage output of the whole string will be equal to the sum of all modules; when the PV modules connect in parallel, the output current will be equal to the sum of each branch current. We suggest that every series PV module string should be fused prior to be connected with other strings. Please refer to the applicable regional and local codes for additional fuse requirements. When necessary, please install blocking diodes to protect PV module or PV system been damaged by reverse current.
- 3.2.5 The module frame is made of anodized aluminum, and therefore corrosion can occur if the module is subject to a salt water environment with contact to a rack of another type of metal (Electrolysis Corrosion). If required, PVC or stainless steel washers can be placed between the PV module frame and support structure to prevent this type of corrosion. Module support structures that are to be used to support PV modules at correct tilt angles should be rated for wind and snow loads and comply with local and civil codes prior to installation.

3.3 Mounting methods

Ulica Solar modules had been passed the static mechanical load test (front side : 3600 pa ; back side :1600 pa ;safe factor:1.5) by the qualified third party institution , can be mounted using the following methods:

Note: All installation methods herein are only for reference, and Ulica solar will not provide related BOS components, the system installer or trained professional personnel must be responsible for the PV system’s design, installation, and mechanical load calculation and security of the system.)

- Using corrosion-proof screws (M8) in the existing installing holes in the module frame.
- Using suitable module clamps on the long side of the module frame to mount the modules (“portrait orientation”).
- Using suitable module clamps on the short side of the module frame to mount the modules (“landscape orientation”).
- Generally , the positive and negative load capacity of each clamping positions

should be over 900Pa and 400Pa respectively. And the positive and negative load capacity of each bolting positions should be over 450Pa and 200Pa respectively.

3.3.1 Bolting mounting:

The frames of each module has 8 mounting holes (Length* Width: 14mm*9mm) used to secure the modules to supporting structure, be sure 8 mounting holes must be used. The module frame must be attached to a mounting rail using M8 corrosion-proof Bolts together with spring washers and flat washers in four symmetrical locations on the PV module. The applied torque should be approximately 8 Newton-meters. Please find detailed mounting information in the below illustration:

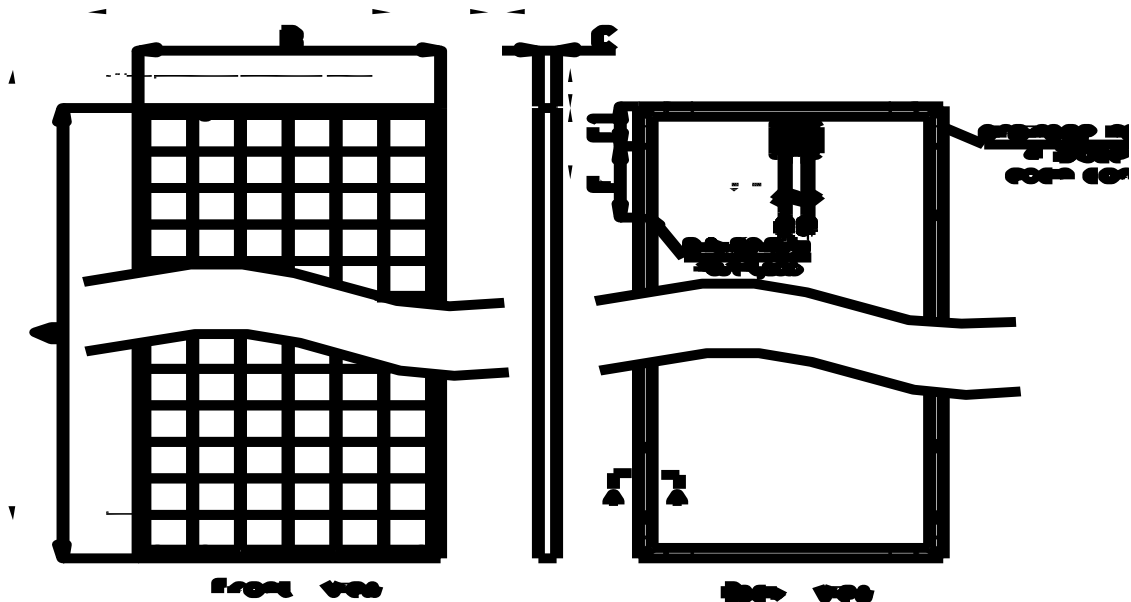
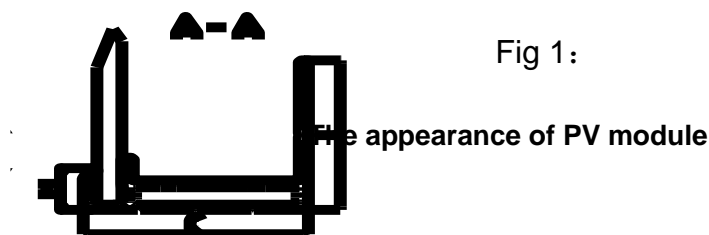

Fig 1:



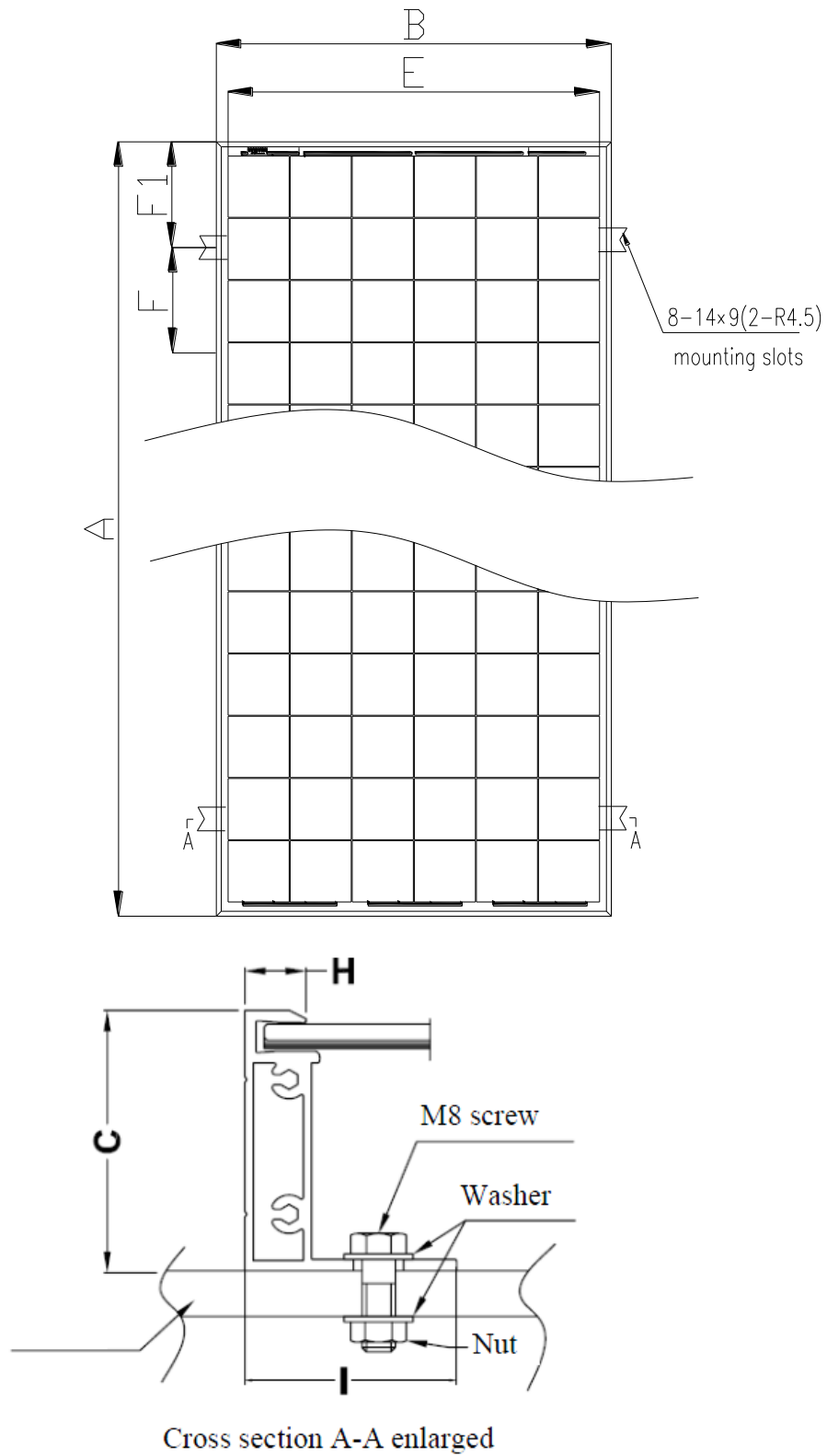

Fig 3:

Figure1~3 PV module installed with Bolt mounting method

Table 1

Module type	Cell type	Cell quantity	Dimensions A*B*C(mm)	Install slot E*F (F1)(mm)	Flame Dimensions H*C*I(mm)
UL-540M-144HV UL-545M-144HV UL-550M-144HV	182*91	6*12*2	2279*1134*35	1084*650 (200)	10*35*35
UL-500M-132HV UL-505M-132HV	182*91	6*11*2	2094*1134*35	1084*650 (200)	10*35*35
UL-405M-108HV UL-410M-108HV UL-415M-108HV	182*9	6*9*2	1724*1134*35	1084*650 (200)	10*35*35

If required, PVC or stainless steel washers can be placed between the PV module frame and support structure to prevent this type of corrosion.

3.3.2 Clamp fitting (portrait orientation):

Use a certain number of clamps to fix the modules on the mounting rail. The module clamps should not come into contact with the front glass and must not deform the frame. Be sure to avoid shadowing effects from the module clamps. The module frame is not to be modified under any circumstances. When choosing this type of clamp-mounting method, please be sure to use at least four clamps on the long frame of module, detailed mounting information as the following illustration. The applied torque should be about 8 Newton-meters.

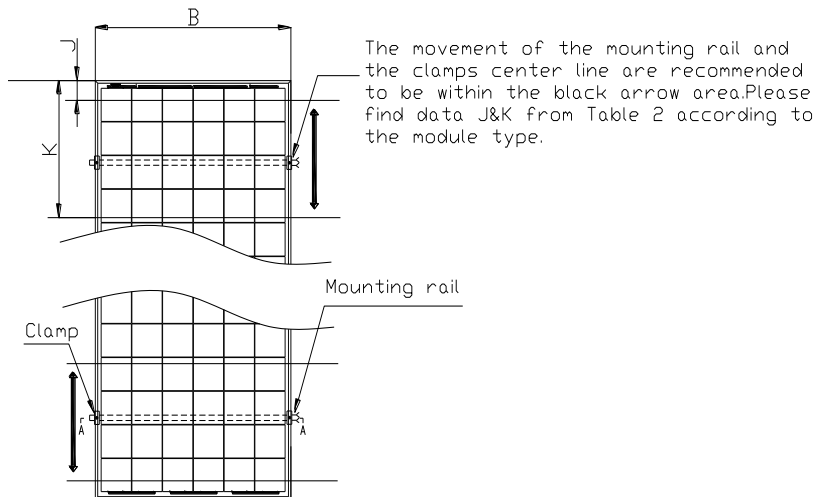

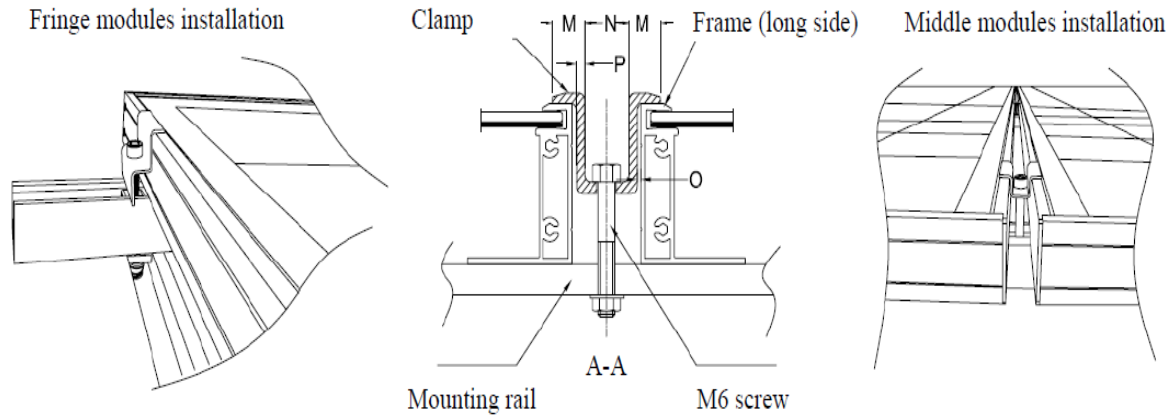

Fig 4:
PV module installed at portrait orientation with Clamp fitting method

Table2

Module type	Cell quantity	Dimensions (mm)						
		A*B	J	K	M	N	O	P
UL-540M-144HV UL-545M-144HV UL-550M-144HV	6*12*2	2279*1134*35	200	650	10	14	0.5-2	2.5-3
UL-500M-132HV UL-505M-132HV	6*11*2	2094*1134*35	200	500	10	14	0.5-2	2.5-3
UL-405M-108HV UL-410M-108HV UL-415M-108HV	6*9*2	1724*1134*35	200	440	10	14	0.5-2	2.5-3

Mechanical load

4 clamps installation .

Test load: positive 5400Pa , negative 3800Pa .

Design load: positive 3600Pa , negative 2534Pa . Safety factor: 1.5 .

3.3.3 Clamp fitting (landscape orientation):

Use a certain number of clamps to fix the modules on the mounting rail. The module clamps should not come into contact with the front glass and must not deform the frame. Be sure to avoid shadowing effects from the module clamps. The module frame is not to be modified under any circumstances. When choosing this type of clamp-mounting method, please be sure to use at least four clamps on the short frame of module, detailed mounting information as the following illustration. The applied torque should be about 8 Newton-meters.

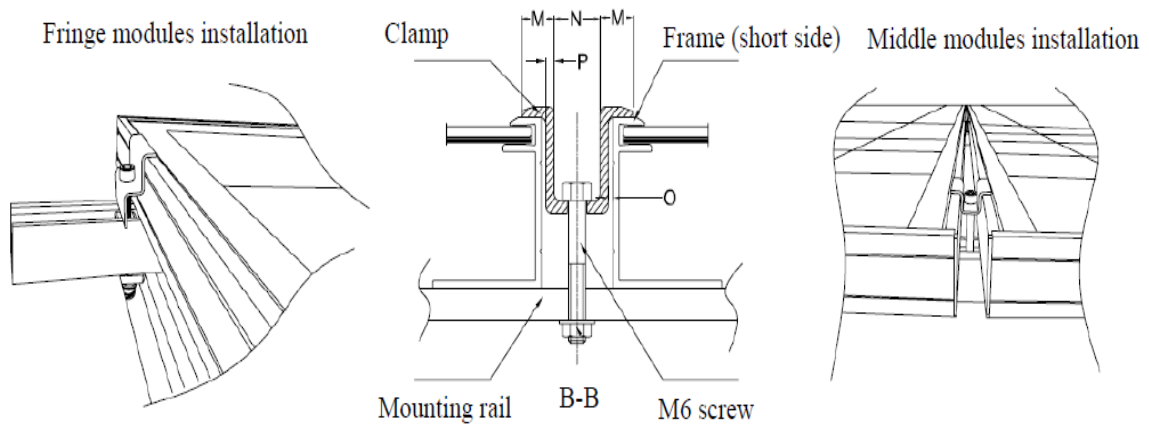
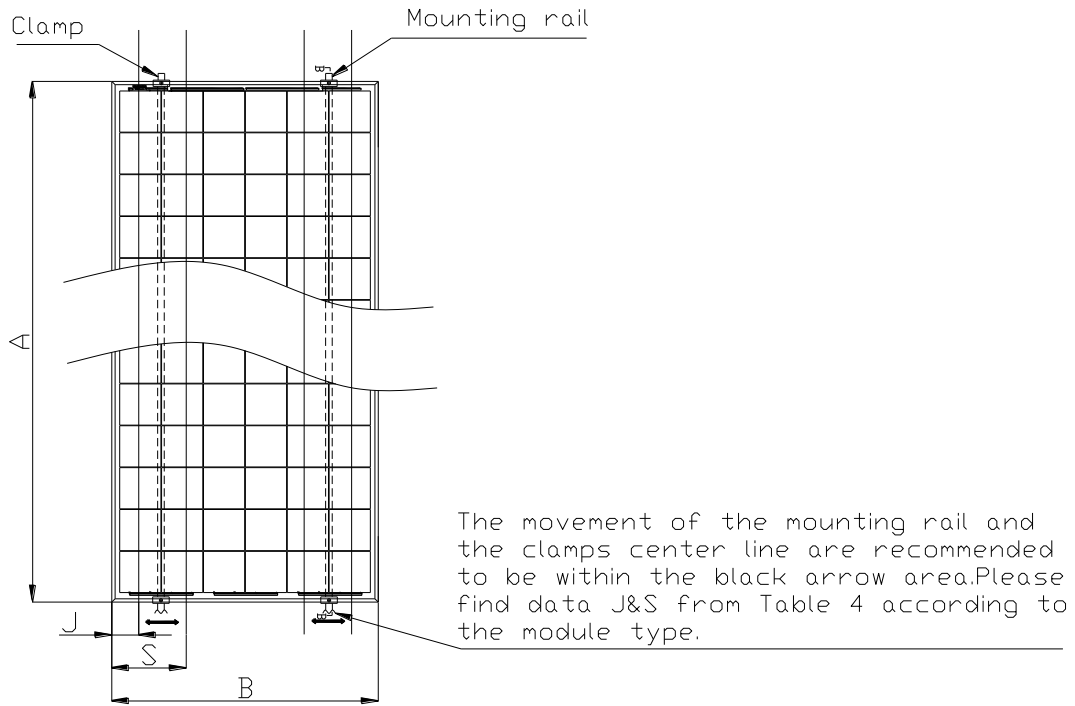

Fig 5:

PV module installed at landscape orientation with Clamp fitting method

Table 3

Module type	Cell quantity	Dimensions (mm)						
		A*B	J	S	M	N	O	P
UL-540M-144HV UL-545M-144HV UL-550M-144HV	6*12*2	2279*1134*35	50	330	10	14	0.5-2	2.5-3
UL-500M-132HV UL-505M-132HV	6*11*2	2094*1134*35	50	330	10	14	0.5-2	2.5-3
UL-405M-108HV UL-410M-108HV UL-415M-108HV	6*9*2	1724*1134*35	50	330	10	14	0.5-2	2.5-3

3.4 roof mounting

Consult your local authority for guidelines and requirements for building or Structural fire safety.

3.4.1 Roof constructions and installations may affect the fire safety of a building; improper installation may create hazards in the event of a fire.

3.4.2 Use components such as ground fault circuit breakers and fuses as required by local authority.

3.4.3 Do not use panels near equipment or in places where flammable gases may be generated.

3.4.4 The modules have been rated Fire Class C, and are suitable for mounting on to a Class A roof.

4. Electrical Installation-Wiring And Notes

4.1 Bypass Diodes

When modules in series are partially shaded, it may cause reverse voltage across cells or modules, this may cause undesirable heating to occur. The use of a diode to bypass the shaded area can minimize both heating and array current reduction.

All Ulcia modules are equipped with factory installed bypass diodes. The factory installed diodes provide proper circuit protection for the system.

When a bypass diode is wired in parallel with the series string, the forced current will flow through the diode and bypass the shaded module, thereby minimizing module heating and array current losses.

Diodes that are used as bypass diodes must:

Have a Rated Average Forward Current above maximum system current at highest module operating temperature.

Have a Rated Repetitive Peak Reverse Voltage above maximum system voltage at lowest module operating temperature.

4.2 Correct wiring scheme

To minimize the risk of indirect lightning strike, avoid forming closed loops when designing the system. Check that wiring is correct before starting the generator. If the measured open circuit voltage (Uoc) and short-circuit current (Isc) differ from the specifications, there may be a wiring fault.

4.3 Correct connection plug connectors

The area of the cable matched with the connector is recommended to be 4~6 mm², length: 900mm, temperature range: -40°C-90°C.. Connectors should only

Be used to connect a pair of cables and female and male connectors. For a series electrical connection, connect positive (+) connector of first PV module to the

negative (-) connector of the following module.

Do not short the positive and the negative of a single PV module. Do not disconnect under load. Be sure connectors have no gap between the insulators. A gap can cause fire hazard and/or danger of an electrical shock. Make sure that the connection is safe and tight. The plug connector should not receive external stress

4.4 Use of proper components

Use cable extensions and plugs that are designed for outdoor applications. Ensure that they are in good electrical and mechanical condition. Only cables with one conductor are to be used. The wires are connected to the connector provided by crimped connection

Ensure that all materials meet the requirements of the systems` maximum voltage, current, moisture, and temperature when they are exposed to sunlight.

Under normal conditions, a photovoltaic module is likely to produce more current and/or voltage than that reported under Standard Test Conditions. Accordingly, the values of I_{sc} and V_{oc} marked on the module should be multiplied by a factor of 1.25 when selecting electrical components voltage ratings, conductor capacities, fuse type, and type of control components connected to the PV output. Refer to Section 690-8 of the U.S.National Electric Code for an additional multiplying factor of 1.25 which may be applicable.

The maximum series fuse rating is 15A (modules with Ulica 156x156 cells) or 20A (modules with ulica 166x166 cells) or 25A (modules with ulica 182x182 cells). And the maximum reverse current is known as series fuse rating multiplied by a factor of 1.35.

Each module (or series string of modules so connected) shall be provided with the maximum series fuse as specified.

4.5 Connect between wire and connector

4.5.1 Use wire stripper to peel off the wire jacket. The length of wire stripping is 7.0 ± 1.0 mm. There is no copper break .Detail as following left two figures



wire stripper



crimping plier

4.5.2 The first put the pin (or socket) U shape on the crimping pliers jaw, the cable peeled on the pin (or socket) u, put in the end, the line of skin tight U shaped opening, and then pressed until the crimping pliers crimping pliers can be free to loosen.(Or use the precision press), Crimping Force ≥ 310 N.

4.5.3 Push the pin into the negative plastic part (Push the socket into the

positive plastic part)which will a voice of clicking. The cable will not take off when pull out lightly. Turn a half circle clockwise. The positive and negative parts can move without obstacles and freely rotate in place. Details as following figures



Pin

socket

4.5.4 The tool 1 is fixed to the negative pole plastic part and Using the tool 2 clockwise to tighten the nut. Torque is 2.0~3.0Nm.



Tool 1

Tool 2

4.5.5 Reference distance as following



4.6 Others

During installation, be sure to tie the cable from the junction box to the mounting substructure with nylon line,etc. to avoid direct contact of the cable with the back surface of the module.

5. GROUNDING METHOD

Adopting the grounding hole method; the peripheral electrophoresis coating of grounding hole is wiped off. When mounting, you can select 8# stainless steel screw to well connect copper wires (diameter 4mm) and modules. The torque rating of screw is 1.2N·m at least. Then, copper wires should be connected with grounding wires.

Note:

The electrical characteristics are within $\pm 3\%$ of the indicated values of I_{sc} , V_{oc} , and P_{max} under standard test conditions (irradiance of $100\text{mW}/\text{cm}^2$, AM 1.5, and a cell temperature of 25°C (77°F)).

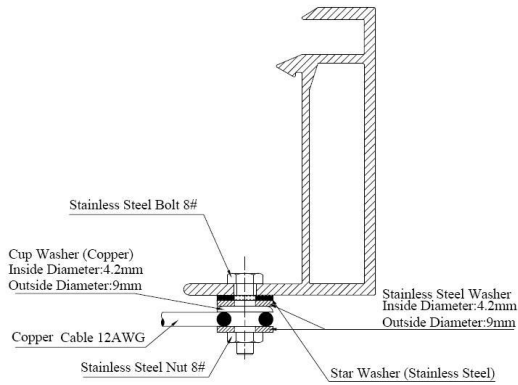

GROUNDING

Fig 6:

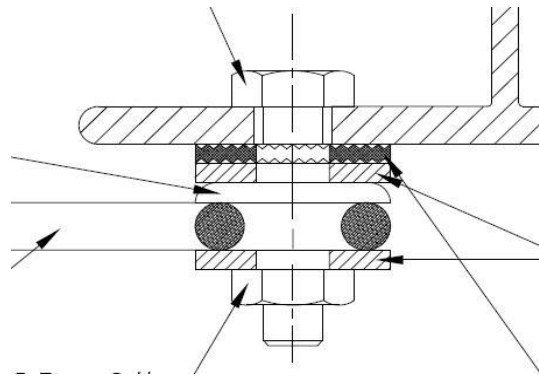

Fig 7:

Declarations:

- ① Each module has two grounding holes (see Fig.8-1, Fig.8-2, Fig.8-3). The symbol is located adjacent to the terminal. The grounding point must be installed separately from the mechanical mountings.

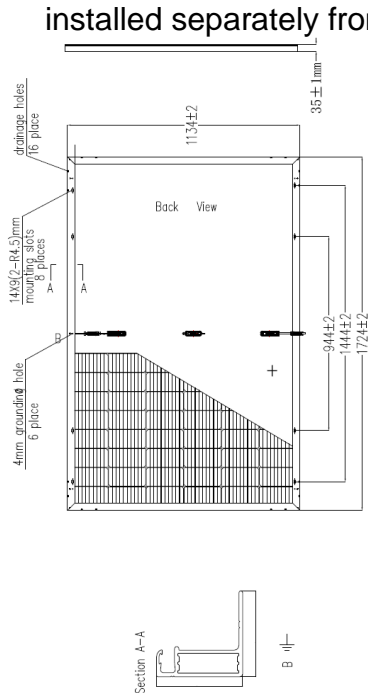

Fig.8-1 UL-XXXM-108HV

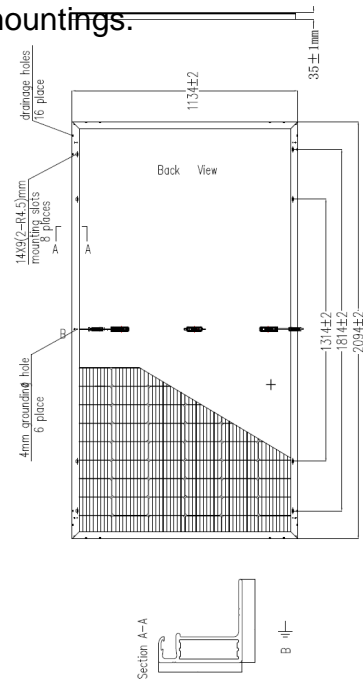

Fig.8-2 UL-XXXM-132HV

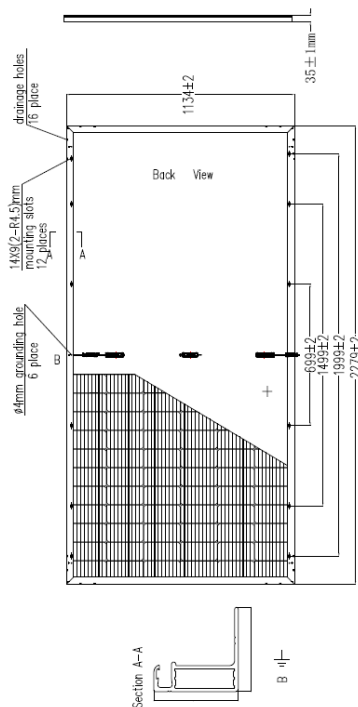

Fig.8-3 UL-XXXM-144HV

- ② We apply a highly visible warning label regarding electrical shock hazard on the means of connection on every single module.

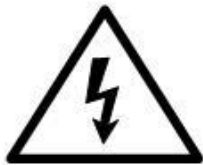

Fig. 9

- ③ The following mentioned are the conditions of the application class A:
 The modules are qualified for Application Class A. Hazardous voltage (IEC 61730: higher than 50VDC; EN 61730: higher than 120V), hazardous power applications (higher than 240W) where general contact access is anticipated (Modules qualified for safety through EN IEC 61730-1 and -2 within this application class are considered to meet the requirements for Safety Class II.)

6. Figure 1 shows a schematic diagram of a cross-section of a photovoltaic module.

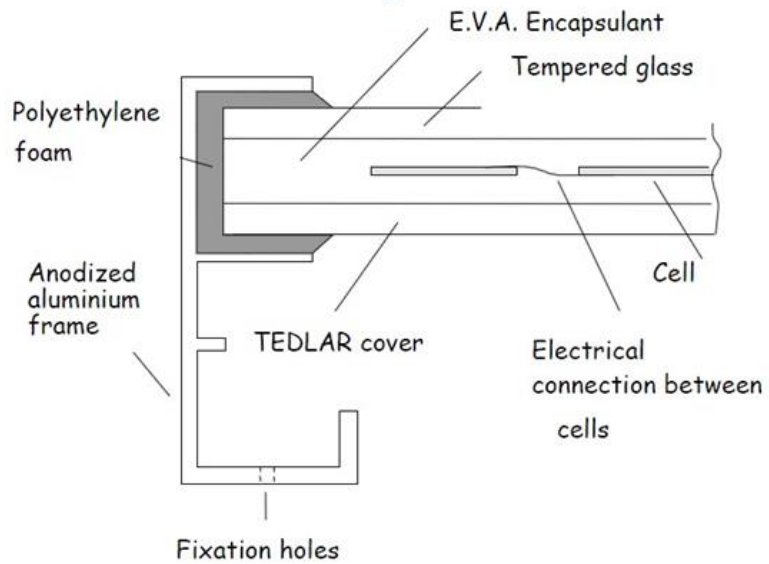

Fig. 10

7. Electrical parameter

Type	Pmax (W) ±3%	Vm	Im	Voc(V) ±4%	Isc(A) ±4%	Module dimension (mm)	Cell dimension (mm)	Array (pcs)	Weight (kg)	Junction box type	Bypass Diode Model /Supplier	Connector type	Cable type				
UL-540M-144HV	540	41.7	12.95	49.8	13.6	2279 x 1134x35	182*91	6×24	28.3	PV-ZH01 1C-5	35SQ045 Zhejiang ZhongHuan Sunter	PV-ZH202B Zhejiang Zhonghuan	62930 IEC131 1×4mm ² Zhejiang Zhonghuan Sunter				
UL-545M-144HV	545	41.8	13.04	49.9	13.65	2279 x 1134x35	182*91	6×24	28.3								
UL-550M-144HV	550	41.9	13.13	50	13.75	2279 x 1134x35	182*91	6×24	28.3								
UL-500M-132HV	500	38.3	13.05	45.7	13.74	2094 x 1134x35	182*91	6×22	26.2								
UL-505M-132HV	505	38.4	13.15	45.8	13.84	2094 x 1134x35	182*91	6×22	26.2								
UL-405M-108HV	405	31.3	12.94	41.4	13.69	1724 x 1134x35	182*91	6×18	22					JM07W	THY4050 Hangzhou Lion Microelectronics Co.,Ltd	PV-JM601A/ PV-JM608 Zhejiang Jiaming	H1Z2Z2-K 1×4mm ² , Zhejiang Jiaming
UL-410M-108HV	410	31.4	13.06	41.5	13.81	1724 x 1134x35	182*91	6×18	22								
UL-415M-108HV	415	31.5	13.17	41.6	13.93	1724 x 1134x35	182*91	6×18	22								
										PV-CY18 08-B	GF3050MG Yangzhou Yangjie	PV-CY03L Zhejiang Chuangyuan	H1Z2Z2-K 1×4mm ² , Zhejiang Chuangyuan				

The electrical characteristics are within ± 3 percent of the indicated values of Isc, Voc and Pmax under standard test conditions (irradiance of 100 mW/cm², AM1.5 spectrum, and a cell temperature of 25°C)

- Safety Standard for Electrical Installations, please refer to national building codes and safety requirements.

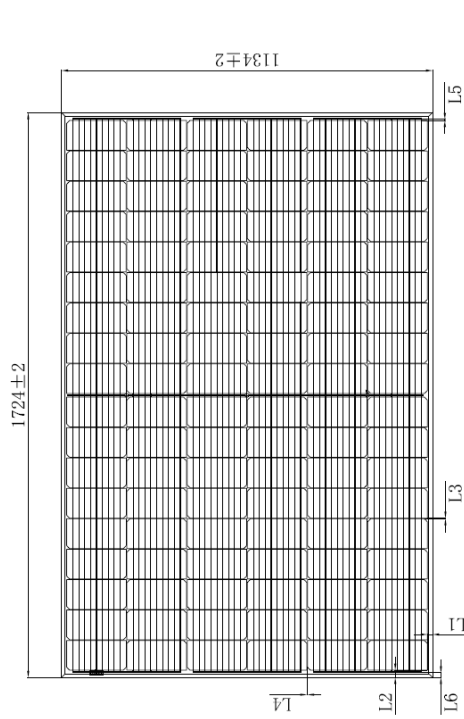

Fig. 11-1 (1724x1134x35)

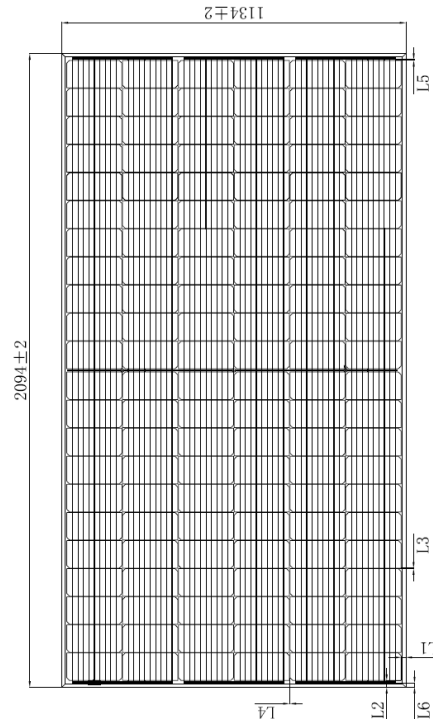

Fig. 11-2 (2094x1134x35)

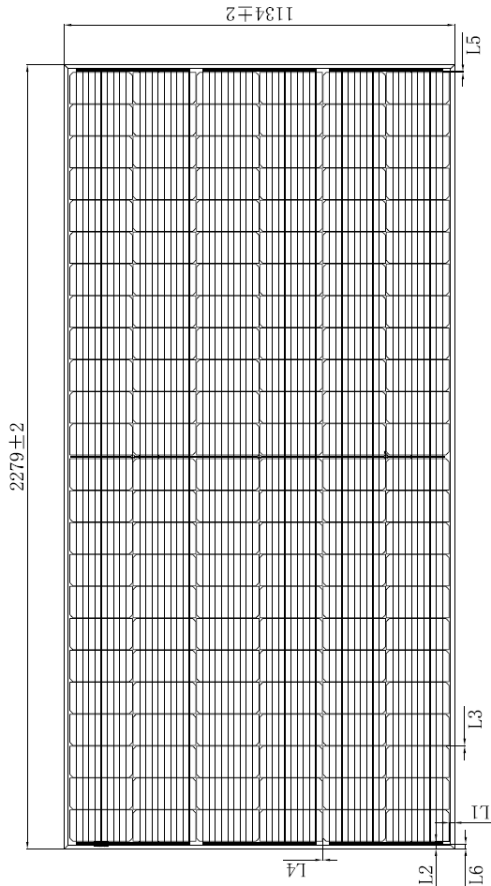

Fig. 11-3 (2279x1134x35)

Distance	Description	Value	Tolerance
L1	From cell edge to frame edge	20.5	±1
L2	From cell edge to frame edge	37	±1
L3	From cell edge to cell edge	2	±0.5
L4	From cell edge to cell edge	3	±1
L5	From bus bar to cell edge	4	±0.5
L6	From bus bar to frame edge	28	±2

The argument of Fig.11-1, Fig.11-2, Fig.11-3.

8. Suggested maximum number of modules in parallel and in series

When designing the system, we recommend that the maximum number of modules in parallel should be no more than two while the maximum number of modules in series no more than the quantity

Cell quantity /module	Maximum number of modules in series (1500V)
108	29
132	26
144	24

9. Battery

When solar modules are used to charge batteries, the battery must be installed in a manner which will protect the performance of the system and the safety of its users. The battery should be away from the main flow of people and animal traffic. Select a battery site that is protected from sunlight, rain, snow, debris, and is well ventilated. Most batteries generate hydrogen gas when charging, which is explosive. Do not light matches or create sparks near the battery bank. When a battery is installed outdoors, it should be placed in an insulated and ventilated battery case specifically designed for the purpose.

10. Maintenance and cleaning

- Do not change the PV components optionally (diode, junction box, plug connectors)
- Given a sufficient tilt (at least 15°), it is not generally necessary to clean the modules (rainfall will have a self-cleaning effect). In case of heavy soiling (which will result in output reductions), we recommend cleaning the modules using plenty of water (from a hose) without cleaning agents and using a gentle cleaning implement (a sponge). Dirt must never be scraped or rubbed away when dry, as this will cause micro-scratches. We recommend that the system be inspected at regular intervals.
- All fastenings are tight and secure and free of corrosion.
- All cable connections are secure, tight, clean and free of corrosion.
- Cables are not damaged in any way.
- Checking the earthing resistivity of metals.

11. Danger of death from electric shock!

Solar modules generate electricity as soon as they are exposed to light. One module on its own is below the safety extra low volt level, but multiple modules connected in series (summing the voltage) or in parallel (summing the current) represent a danger. The following points must be observed when handling the solar modules to avoid the risk of fire, sparking and fatal electric shock.

- **Do not insert electrically conducting parts into the plugs or sockets!**
- **Do not fit solar modules and wiring with wet plugs and sockets!**
- **Exercise utmost caution when carrying out work on wiring and safety equipment (use insulated tools, insulated gloves, etc.)!**
- **Do not use damaged modules! Do not dismantle modules! Do not mark on the rear of the module using sharp objects!**
- **Exercise utmost caution when working on wiring and the inverter. Be sure carefully to follow manufacture's installation instructions!**

Danger of death from arcing !

Modules generate direct current when light shines on them. An arc may be produced when connections are separated. We therefore recommended covering modules with a lightproof cloth during installation. When breaking a

connected string of modules (e.g. when disconnecting the DC line from the inverter under load), a lethally strong arc can occur:

- **Never disconnect the solar generator from the inverter while the inverter is connected to the mains grid—remove the fuse from the AC side on the inverter first!**
- **Ensure cable connections in perfect condition (no splitting, soiling or other contamination)!**

Remark: all size are based in mm unit, and the tolerance is +/- 2 mm

12. Handle safety and Transport

12.1 Do not lift the module by grasping the module's junction box or electrical leads.

12.2 Do not stand, step or walk on any side of the module.

12.3 Do not drop the module or allow objects to fall on the module.

12.4 Do not place any heavy objects on the module.

12.5 Be cautious when placing the module down onto a surface, particularly when placing it in a corner.

12.6 Inappropriate transport and installation may break the module and void the warranty.

12.7 Do not attempt to disassemble the modules, and do not remove any attached nameplates or components from the modules.

12.8 Do not apply paint or adhesive to the module top surface or backsheet.

12.9 Don't hit the module or its package during handle and transport.

12.10 Do not drill holes in the frame. This may compromise the frame strength, cause corrosion of the frame and void the warranty.

12.11 Do not scratch the anodized coating of the frame (except for grounding Connection) . It may cause corrosion of the frame or compromise the frame strength.

12.12 Do not stamp on the front and back of the modules.

12.13 A panel with broken glass or torn backsheet cannot be repaired and must not be used since contact with any panel surface or the frame can cause an electric shock.

12.14 Work only under dry conditions, and use only dry tools. Do not handle panels under wet conditions unless wearing appropriate protective equipment.

12.15 When storing uninstalled panels outdoors for any period of time, always cover the panels and ensure that the glass faces down on a soft flat surface to prevent water from

Ningbo Ulica Solar Co.,Ltd
No.181-197, Shanshan Road, Wangchun Industry District,
Ningbo 315177, P.R.China
TEL: 0574-2882893